

INSTRUCTION

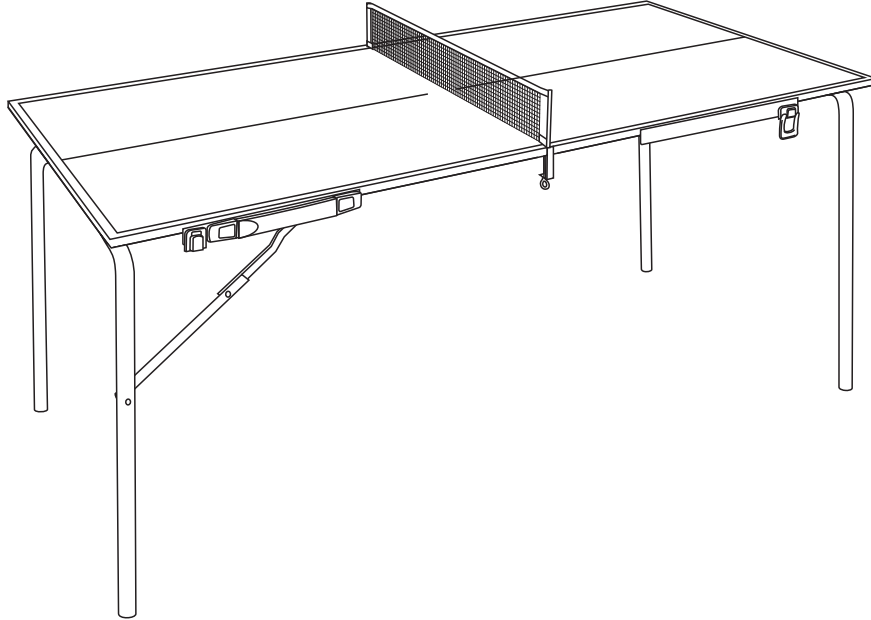

OPEN

Adjust the leg perpendicular to the ground slightly & keep the top horizontal.

A1

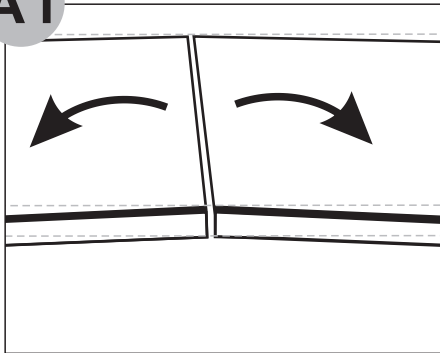

A2

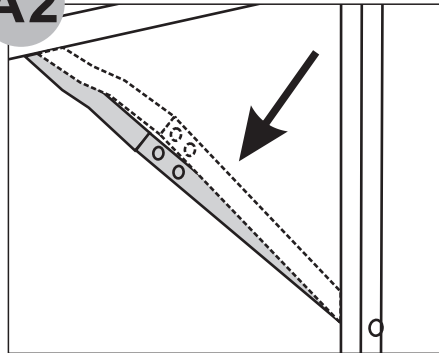

A3

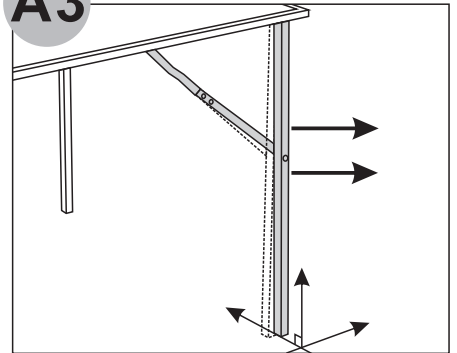

A4

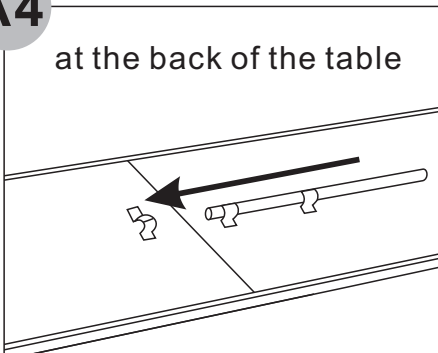

B1

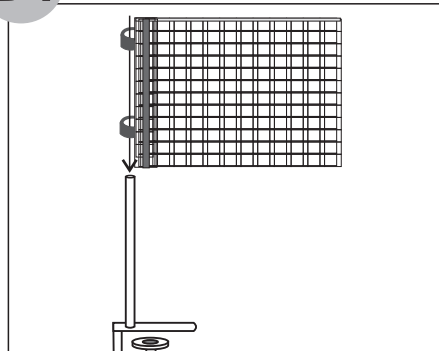

B2

